

BS-1008 Monocular Zoom Microscope Lens



Introduction

BS-1008 adopts semi-apochromatic parallel optical imaging system, and uses advanced multi-layer coating technology, which perfectly correct the imaging on the edge of field of view, get high-resolution and high contrast images, and naturally restore the true colors of observed objects.

For applications that require different magnification, [Auxiliary Lens](#) or infinity objectives with different magnification can be attached to the front end of the [Middle Zoom Module](#).

For application that require different sensor size, [TV Lens](#) with different magnification can be attached to the back end of the [Middle Zoom Module](#).

The basic module of [BS-1008](#) is [BS-1008A](#)(does not have stop) and [BS-1008B](#)(has stop at main magnification), it has 0.7X to 5.6X zoom range and 1:8 zoom ratio. It is a high-quality precision [Monocular Zoom Objective](#) that provides high resolution and large depth of field.

Features

Its main features are shown below:

1. Provide basic zoom objective BS-1008A with 0.7X~5.6X zoom range
2. Large optical zoom ratio: 1:8
3. Larger NA: 0.018-0.092 (When using 1x Auxiliary Lens)
4. Higher resolution: 18.6um-3.65um (When using 1x Auxiliary Lens)

5. Larger field of view: 0.99mm-31.74mm(Object plane)
6. Larger sensor size: 2/3" (When using 1x TV Lens)
7. Working distance: 37.5mm-160mm
8. Parfocal in zoom range
9. Compatible with infinity objectives (both biological and metallographic)
10. Compact size: 150 mm (length) × 40 mm (diameter)
11. Auxiliary Lens with 0.50x, 0.75x, 1.00x, 1.50x and 2.00x magnification (Optional)
12. TV Lens with 0.50x, 0.75x, 1.00x, 1.50x and 2.00x magnification (Optional)
13. Intensity adjustable LED Direct Ring Light (Optional)
14. Intensity adjustable LED Direct Ring Polarization Light (Optional)
15. Intensity adjustable LED coaxial illumination (Optional)
16. 45mm or 50mm Bracket Adapter (Optional)

The dimensions of **BS-1008A** with different light a) **BS-1008A** without light module; b) **BS-1008A** equipped with **Direct Ring Light Module**, c) **BS-1008A** equipped with **Coaxial Light Module** are showed as follows. The length of **BS-1008A** is 150.3mm, it is much shorter than most of the **Monocular Zoom Objective** in the market.

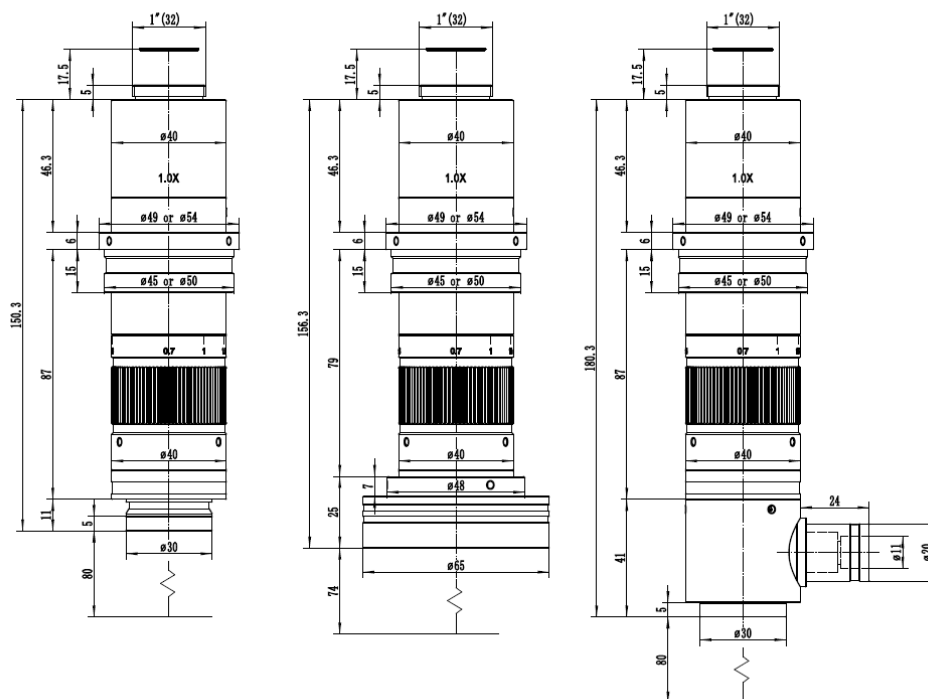

Dimensions of BS-1008A with different light

- a)BS-1008 without light module; b)BS-1008 equipped with Direct Ring Light Module; c)BS-1008 equipped with Coaxial Light Module

Specifications

The specifications of **BS-1008** with different **Auxiliary Lens** and **TV Lens** are shown in Table 1. **Auxiliary Lens** and **TV Lens** with 1.0x are listed in the left-up cell. Its data is the basis of the other parameters in the whole table.

Table 1 BS-1008A/B and Its Extensions

Auxiliary Lens	Specs	TV Lens									
		1.0X (For 2/3" Sensors)		0.5X (For 1/3" Sensors)		0.75X (For 1/1.8" Sensors)		1.5X (For 1" Sensors)		2.0X (For 4/3" Sensors)	
		TV100		TV050		TV075		TV150		TV200	
		Low	High	Low	High	Low	High	Low	High	Low	High
1.0X (80mm WD) W100	PMAG	0.70X~5.60X		0.35X~2.80X		0.53X~4.20X		1.05X~8.40X		1.40X~11.20X	
	FOV	15.8mm	1.96mm	15.8mm	1.96mm	15.8mm	1.96mm	15.8mm	1.96mm	15.8mm	1.96mm
	NA	0.018	0.092	0.018	0.092	0.018	0.092	0.018	0.092	0.018	0.092
0.5X (160mm WD) W050	PMAG	0.35X~2.80X		0.18X~1.40X		0.26X~2.10X		0.53X~4.20X		0.70X~5.60X	
	FOV	31.74mm	3.93mm	31.74mm	3.93mm	31.74mm	3.93mm	31.74mm	3.93mm	31.74mm	3.93mm
	NA	0.009	0.046	0.009	0.046	0.009	0.046	0.009	0.046	0.009	0.046
0.75X (105mm WD) W075	PMAG	0.53X~4.20X		0.26X~2.10X		0.40X~3.15X		0.79X~6.30X		1.05X~8.40X	
	FOV	20.99mm	2.61mm	20.99mm	2.61mm	20.99mm	2.61mm	20.99mm	2.61mm	20.99mm	2.61mm
	NA	0.013	0.069	0.013	0.069	0.013	0.069	0.013	0.069	0.013	0.069
1.5X (51.5mm WD) W150	PMAG	1.05X~8.40X		0.53X~4.20X		0.79X~6.30X		1.58X~12.60X		2.10X~16.80X	
	FOV	10.46mm	1.31mm	10.46mm	1.31mm	10.46mm	1.31mm	10.46mm	1.31mm	10.46mm	1.31mm
	NA	0.026	0.138	0.026	0.138	0.026	0.138	0.026	0.138	0.026	0.138
2.0X (37.5mm WD) W200	PMAG	1.40X~11.20X		0.70X~5.60X		1.05X~8.40X		2.10X~16.80X		2.80X~22.40X	
	FOV	7.90mm	1.00mm	7.90mm	0.99mm	7.90mm	0.99mm	7.90mm	0.99mm	7.90mm	0.99mm
	NA	0.035	0.182	0.035	0.182	0.035	0.182	0.035	0.182	0.035	0.182
Remarks	When using coaxial lighting, low magnification may produce vignetting. When using infinity objectives as Auxiliary Lens Module (adapter available), the PMAG , FOV and NA of the BS-1008 depends on the parameters of the objectives.										

WD: Working Distance;

PMAG: Primary Magnification;

FOV: Field of View in the Object side;

NA: Numerical Aperture;

Note: Infinity corrected objectives limit system's usable zoom range due to uneven illumination. Max sensor format is 2/3".



BS-1008-W100-TV050-A45, BS-1008-W100-TV075-A45 and BS-1008-W100-TV100-A45 photo (W100 indicates that BS-1008 is equipped with 1x auxiliary objective, TV050 is 0.5x TV lens, TV075 is 0.75x TV lens, and TV100 is 1.0x TV lens, A45 means the mounting adapter ring is 45mm. It is not difficult to find that the length of TV lens increases with the increase of TV lens magnification).

Application

BS-1008 is an ideal choice for most applications that require multiple magnifications or for those that prohibit continual manual refocusing. The applications of the BS-1008 are:

1. Machine vision
2. Small details inspection
3. Industrial inspection especially electronic components
4. Scientific research
5. Medical industry
6. Education industry

Available Accessories

1. How to Configure BS-1008 Monocular Zoom Objective

- (1) Confirm the possible range of 1) **FOV** and 2) **Working Distance** in the object space to choose the **Auxiliary Lens**;
- (2) Choose the M26x0.705 to M20x0.705 Objective Adapter, if the M20x0.705 infinity objective is used;
- (3) Confirm the camera **Image Area Size**, it can be 1) **Sensor Size** (1/x in inch), 2) **Image Diagonal Length**, 3) **Image Width** or 4) **Image Height** to choose the **TV Lens**;
- (4) Choose the 45mm or 50 mm adapter according to the diameter of the hole in the bracket;
- (5) Choose the **LED Direct Ring Light Module** for the reflective illumination;
- (6) Choose the **Coaxial Light Module** if coaxial illumination is required;

- (7) Choose the [Transmitted Light Module](#) if Transmitted illumination is required;
(8) Choose the [Camera Module](#).

2. Configuration of BS-1008

The available components are listed in Table 2, user can choose any part from the table.

Table 2 BS-1008's Accessories and Its Functions

Module	Order Number	Description
Auxiliary Lens Module	BS-1008W050	0.50x Object Lens
	BS-1008W075	0.75x Object Lens
	BS-1008W100	1.0x Object Lens
	BS-1008W150	1.5x Object Lens
	BS-1008W200	2.0x Object Lens
	ON-XX	Biological Objective
	ON-YY	Metallographic Objective
	Objective Adapter	M26x0.706 to M20x0.706
Middle Zoom Module	BS-1008	The main body of BS-1008
TV Lens Module	BS-1008TV040	0.4XTV Lens
	BS-1008TV050	0.5XTV Lens
	BS-1008TV075	0.75X TV Lens
	BS-1008TV100	1.0XTV Lens
	BS-1008TV150	1.5X TV Lens
	BS-1008TV200	2.0XTV Lens
Coaxial Light Module	BS-1008CL+BS-1008SL	Coaxial Light Adapter + LED Spot Light
LED Direct Ring Light Module	BS-1008DRL	LED Direct Ring Light
	BS-1008DRPL	LED Direct Ring Polarization Light
Transmitted Light Module	BS-1008TL	LED Transmitted Light
Bracket Adapter	BS-1008A45	45mm Bracket Adapter (mounting adapter)
	BS-1008A50	50mm Bracket Adapter (mounting adapter)
Power of light source	40600014	POWER-U-12V1A, Power Adapter American Standard
	40600015	POWER-E-12V1A, Power Adapter European standard

Configuration

System Decomposition Diagram

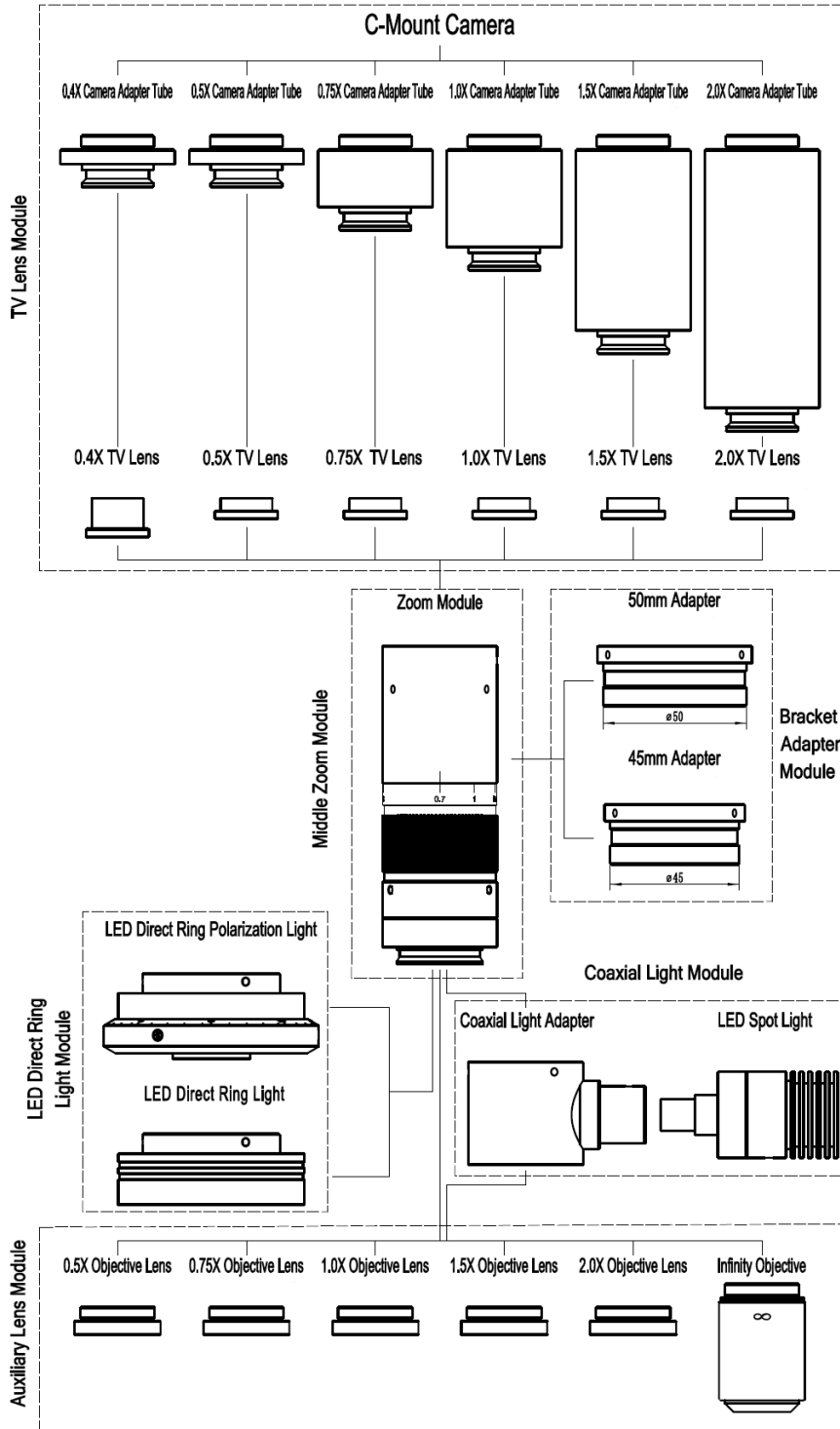

The Basic and Optional Modules of the Monocular Zoom Objective

The **BS-1008** main body consists of **Auxiliary Lens Module**, **Middle Zoom Module** and **TV Lens Module**.

These 3 modules comprise the main **Monocular Zoom Objective**. User can choose different **Auxiliary Lens** and **TV Lens** to satisfy the specific requirement.

To get good illumination and ensure the image quality, **LED Direct Ring Light Module** (Optional) or **Coaxial Light Module** (Optional) should be chosen according to the application.

To get good and stable support, the **Bracket Adapter Module** should be carefully chosen.

Finally, to form the **Video Monocular Zoom Objective**, **Camera Module** (Optional) should be chosen.

The **Adapter Rings** and their relationship with the **Bracket** are shown in Error: Reference source not found.

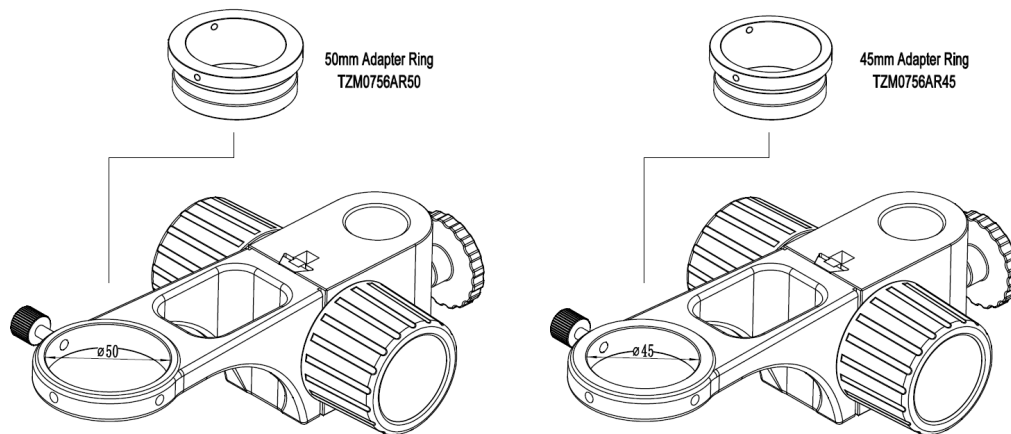

BS-1008 Adapter Ring for the Bracket

The **Direct Ring Light**, **Direct Ring Polarization Light** and the **Coaxial Light** are shown in following figures respectively.



BS-1008DRL, LED Direct Ring Light. Its interface matches with BS-1008



BS-1008DRPL, LED Direct Ring Polarization Light. Its interface matches with BS-1008



BS-1008CL(Coaxial Light Adapter)+BS-1008SL(LED Spot Light)



BS-10A Stand



BS-20A Stand

Connection between BS-1008 and Camera



BS-1008-W100-TV050+BS-1008DRL(LED Direct Ring Light Module)+HDMI Camera



BS-1008-W100-TV050+BS-1008DRPL(LED Direct Ring Polarization Light)+HDMI Camera



BS-1008-W100-TV050+BS-1008CL+ BS-1008SL(Coaxial Light Module)+ HDMI Camera



BS-1008-W100-TV050+BS-1008DRL(LED Direct Ring Light)+USB CMOS Camera



BS-1008-W100-TV050+BS-1008DRPL(LED Direct Ring Polarization Light)+USB CMOS Camera



BS-1008-W100-TV050+BS-1008CL+BS-1008SL(Coaxial Light Module)+ USB CMOS Camera

Packing List

The package information of [BS-1008](#) is as follows:



BS-1008 Main Body, including Auxiliary Lens Module, Middle Zoom Module, TV Lens, Camera Adapter Tube and Bracket Adapter

The package information of [BS-1008DRL](#) is as follows:



BS-1008DRL, including LED Direct Ring Light and Power Adapter

The package information of [BS-1008DRPL](#) is as follows:



BS-1008DRPL, including LED Direct Ring Polarization Light and Power Adapter

The package information of [Coaxial Light Module](#) is as follows:



BS-1008 Coaxial Light Module, including BS-1008CL(Coaxial Light Adapter), BS-1008SL(LED Spot Light) and Power Adapter

Model List of BS-1008

The below table has listed the possible combination of the [BS-1008](#) with [Auxiliary Lens](#) and [TV Lens](#). Users can quickly decide the model they need to purchase according to their existing cameras, the required [Working Distance](#) (WD), the [Primary Magnification](#) (PMAG) or the diagonal field of view ([FOV](#)) of the observation object.

Model of BS-1008

Camera Size	BS-1008 Model	WD (mm)	Zoom Range	FOV (mm)	N.A.
1/3"	BS-1008-W050-TV050	160	0.18X-1.40X	31.74-3.93	0.009-0.046
	BS-1008-W075-TV050	105	0.26X-2.10X	20.99-2.61	0.013-0.069
	BS-1008-W100-TV050	80	0.35X-2.80X	15.80-1.96	0.018-0.092
	BS-1008-W150-TV050	52	0.53X-4.20X	10.46-1.31	0.026-0.138
	BS-1008-W200-TV050	38	0.70X-5.60X	7.90-0.99	0.035-0.182
1/1.8"	BS-1008-W050-TV075	160	0.26X-2.10X	31.74-3.93	0.009-0.046
	BS-1008-W075-TV075	105	0.40X-3.15X	20.99-2.61	0.013-0.069
	BS-1008-W100-TV075	80	0.53X-4.20X	15.80-1.96	0.018-0.092
	BS-1008-W150-TV075	52	0.79X-6.30X	10.46-1.31	0.026-0.138

	BS-1008-W200-TV075	38	1.05X-8.40X	7.90-0.99	0.035-0.182
2/3"	BS-1008-W050-TV100	160	0.35X-2.80X	31.74-3.93	0.009-0.046
	BS-1008-W075-TV100	105	0.53X-4.20X	20.99-2.61	0.013-0.069
	BS-1008-W100-TV100	80	0.70X-5.60X	15.80-1.96	0.018-0.092
	BS-1008-W150-TV100	52	1.05X-8.40X	10.46-1.31	0.026-0.138
	BS-1008-W200-TV100	38	1.40X-11.2X	7.90-0.99	0.035-0.182
1"	BS-1008-W050-TV150	160	0.53X-4.20X	31.74-3.93	0.009-0.046
	BS-1008-W075-TV150	105	0.79X-6.30X	20.99-2.61	0.013-0.069
	BS-1008-W100-TV150	80	1.05X-8.40X	15.80-1.96	0.018-0.092
	BS-1008-W150-TV150	52	1.58X-12.6X	10.46-1.31	0.026-0.138
	BS-1008-W200-TV150	38	2.10X-16.8X	7.90-0.99	0.035-0.182
4/3"	BS-1008-W050-TV200	160	0.70X-5.60X	31.74-3.93	0.009-0.046
	BS-1008-W075-TV200	105	1.05X-8.40X	20.99-2.61	0.013-0.069
	BS-1008-W100-TV200	80	1.40X-11.2X	15.80-1.96	0.018-0.092
	BS-1008-W150-TV200	52	2.10X-16.8X	10.46-1.31	0.026-0.138
	BS-1008-W200-TV200	38	2.80X-22.4X	7.90-0.99	0.035-0.182

The **Working Distance** of BS-1008 decreases with the increase of the magnification of the **Auxiliary Lens**, and its object **NA** or **Zoom Range** increases with the increase of the magnification of the **Auxiliary Lens**. Therefore, the **Auxiliary Lens** can be selected according to the **Working Distance** or **Zoom Range** (The real **Zoom Range** is also determined by the **Auxiliary Lens**).

The core of choosing **TV Lens** with different magnification is to match your own camera. From the table's **Zoom Range** column, one can find with the increase of **TV Lens'** magnification, the **Zoom Range** of the system increases in the same proportion, but it will not have a great effect on the optical resolution. In order to save money, it is recommended to choose a small size camera, such as 1/3" camera.

Of course, in order to improve the signal-to-noise ratio or imaging quality of the camera, one can also choose a large size camera. Large size often means large pixel size, while large pixel size often means large dynamic range and high signal-to-noise ratio.

Sample Images of BS-1008 under Different Light Illuminations

Below pictures of coins taken by BS-1008W100-TV05 with different illumination. From left to right, left: LED Direct Ring Light Illumination; middle: LED Direct Ring Polarization Light Illumination; right: Coaxial Light Illumination.



Pictures of CMOS image sensor taken with BS-1008 under LED Direct Ring Light Illumination and Coaxial Light

Illumination (5.6X PMAG)

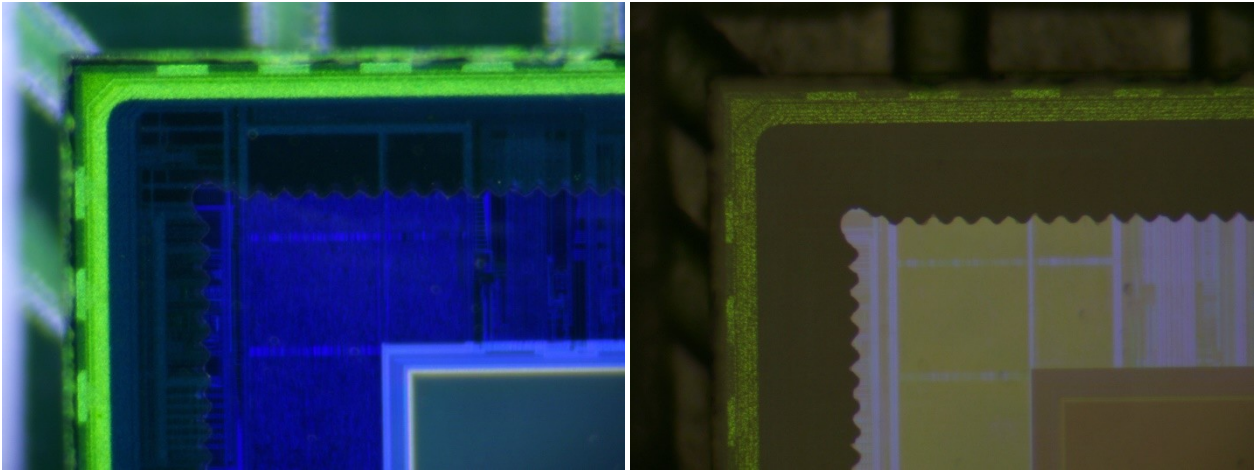

Pictures of circuit board taken by BS-1008 with LED Direct Ring Light Illumination, when shooting the left picture, the magnification of BS-1008 is 0.7X, when shooting the right picture, the magnification of BS-1008 is 2.5X.

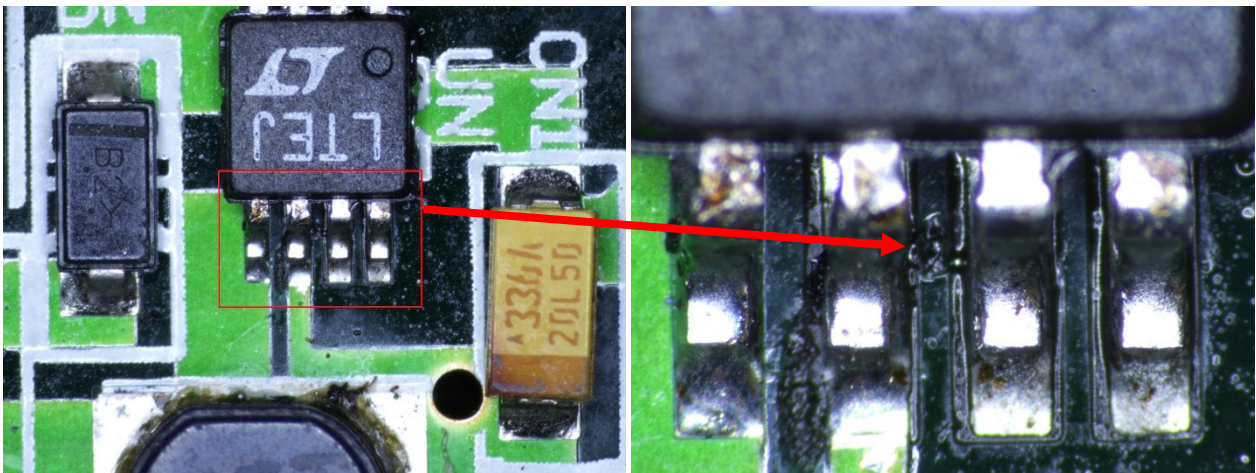

Mobile phone pixels taken by BS-1008, under 2.5X PMAG and 5.6X PMAG

